

--	--	--	--	--	--	--	--	--	--

Sixth Semester B.E. Degree Examination, June/July 2023 Design of Machine Elements – II

Time: 3 hrs.

Max. Marks: 100

- Note: 1. Answer any FIVE full questions, choosing ONE full question from each module.
2. Using design data hand book is permitted.
3. Assume missing data suitably.*

Module-1

- 1 a. Discuss about the following terms :
- (i) Active coils
 - (ii) Deflection
 - (iii) Solid length
 - (iv) Free length
 - (v) Resilience
- (05 Marks)
- b. Derive an expression for energy stored in a spring. (05 Marks)
- c. Design a helical compression spring to carry a load of 500 N with a deflection of 20 mm. The allowable shear stress in the spring material is 350 MN/m² and the modulus of rigidity is 82.7×10^3 MN/m². The spring index is 6. (10 Marks)

OR

- 2 a. A leather belt 125 mm wide and 6 mm thickness transmits power from a pulley 750 mm diameter which runs at 500 rpm. The angle of lap is 150° and the coefficients of friction between the belt and the pulley is 0.3. If the belt density is 1000 kg/m³ and the stress in the belt is not to exceed 2.75 N/mm², find the power that can be transmitted by the belt. Also find the initial tension in the belt. (10 Marks)
- b. An oil well has to be drilled to a depth of 900 mm using 100 drill pipe. Assume 200 N for every 15 m length of pipe. The rope sheaves are of 80 mm diameter and acceleration is 2.5 m/s². Determine the size of 6×37 wire rope for lifting the string of pipes using a FOS as 3 and ultimate stress as 1800 MPa. (10 Marks)

Module-2

- 3 Design a pair of spur gear to transmit 27 kW for an oil pump with the gear ratio of 3 : 1, the rpm of the pinion is 1200, the centre distance is 400 mm, and the gears are to be forged steel untreated with $14\frac{1}{2}^\circ$ FDI. Check the design for dynamic and wear condition. (20 Marks)

OR

- 4 A pair of helical gears are used to transmit 15 kW. The teeth are 20° full depth in normal plane and have a helix angle of 30°. The pinion has 24 teeth and operates at 1000 rpm. The velocity ratio is 5 to 1. The pinion is made of cast steel [$\sigma_d = 50$ MPa] and the gear is of bronze [$\sigma_d = 40$ MPa]. The pinion material is hardened to 200 BHN. Design the gear pair. (20 Marks)

Module-3

- 5 A pair of straight tooth bevel gear at right angle is to transmit 5 kW at 1200 rpm of the pinion. The diameter of the pinion is 80 mm and the velocity ratio is 3.5 to 1. The tooth form is $14\frac{1}{2}^\circ$ composite type. Both pinion and gear are made of CI $[\sigma_d = 55 \text{ N/mm}^2]$. Determine the face width and the required module from the stand point of strength using Lewis equation and check for design from the stand point of dynamic load and wear load. (20 Marks)

OR

- 6 Design a worm gear to transmit 2 kW at 1000 rpm, speed ratio is 20 and centre distance is 200 mm. (20 Marks)

Module-4

- 7 a. A cone clutch with a face angle of 14° has to transmit 286 N-m of torque at a speed of 600 rev/min. The larger diameter of the clutch is 250 mm, face width is 60 mm and co-efficient of friction is 0.18. Determine (i) Axial force to transmit the torque (ii) Average normal pressure (iii) Maximum normal pressure. Assume uniform wear condition. (10 Marks)
- b. A single plate friction clutch of both sides effective has 0.3 m outer diameter and 0.16 m inner diameter. The coefficient of friction is 0.2 and it runs at 1000 rpm. Find the power transmitted for uniform wear and uniform pressure distribution cases if the allowable maximum pressure is 0.08 MPa. (10 Marks)

OR

- 8 a. Fig. Q8 (a) shows a CI brake shoe. The coefficient of friction is 0.30. The braking torsional moment is to be 346 N. Determine
 (i) The force P, for anti-clock wise rotation.
 (ii) The force P, for clockwise direction.
 (iii) Where must the pivot be placed to make the brake self energizing with the counter clockwise direction.

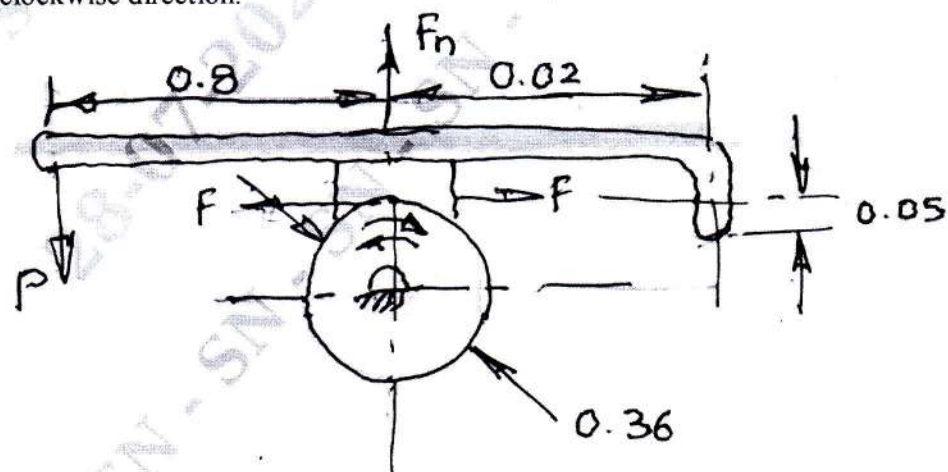

Fig. Q8 (a)

(10 Marks)

- b. In a simple band brake, the length of the lever is 440 mm, the tight end of the band is attached to the fulcrum of the lever and the slack end to a pin 50 mm from the fulcrum. The diameter of the break drum is 1 m and arc of contact is 300° , the co-efficient of friction between the band and the drum is 0.35. the break drum is attached to a hoisting drum of diameters 0.65 m that sustains a load of 20 kN (Fig. Q8(b)),
- Force required at the end of lever to support the load.
 - Width of steel band if the tensile stress is limited to 50 N/mm^2 .

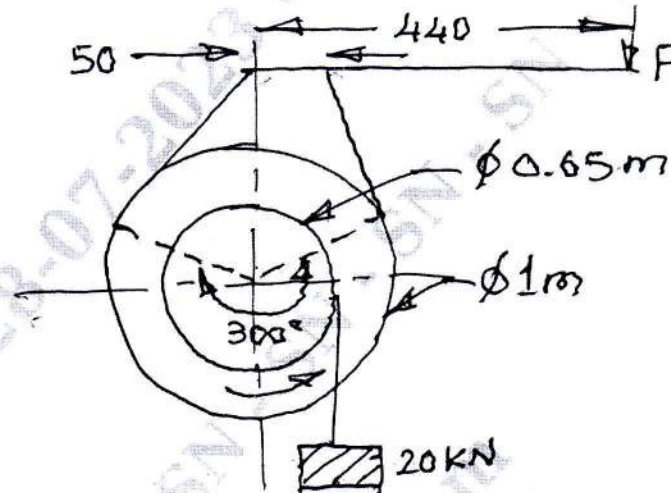

Fig. Q8 (b)

(10 Marks)

Module-5

- Derive Petroff's equation for lightly loaded bearing. (12 Marks)
- For a full journal bearing has the following specification : Shaft diameter 45 mm, bearing length 66 mm, Clearance ratio 0.0015, Speed 2800 rpm, Load 800 N and absolute viscosity $8.27 \times 10^{-3} \text{ Pa}\cdot\text{s}$. Determine (a) frictional torque (b) Co-efficient of friction (c) Power loss. (08 Marks)

OR

- A full journal bearing of 50 mm diameter and 100 mm long has a bearing pressure of 1.4 N/mm^2 . The speed of journal is 900 rpm and the ratio of journal diameter to the diametrical clearance is 1000. The bearing is lubricated with oil whose absolute viscosity at the operating temperature of 75°C may be taken as 0.011 kg/m . The room temperature is 35°C . Determine :
 - The amount of artificial cooling required.
 - The mass of lubricating oil required, if the difference between outlet and inlet temperature of the oil is 10°C .
 Take specific heat of $1850 \text{ J/kg}^\circ \text{K}$. (10 Marks)
- A bearing for an axial flow compressor is to carry a radial load of 4905 N and thrust load of 2452 N. The service imposes light shock and the bearing is used for 40 hours/week for 5 years. The speed of the shaft is 300 rpm and diameter of the shaft is 60 mm. Select a suitable bearing. (10 Marks)
